

TO: ALL ROOTES DEALERS

MODEL: SUPER MINX III, MINX V
(FLOOR GEAR CHANGE & BORG WARNER
MODELS ONLY)

SUBJECT: TRAFFICATOR SWITCHES

Within the Chassis Number range shown below, a modified type of trafficator switch striker was introduced.

This consists of a WHITE Delrin striker bush (B) positioned in the top of the outer column and a metal driving link (A) as shown on the accompanying illustration. The trafficator switch remains the same as previously fitted to these models.

Where difficulties are encountered with the trafficator switch mechanism on these cars, proceed as follows:-

1. Too shallow striker engagement giving lack of trip or too deep engagement causing trafficator to trip onto the opposite lock. DISCARD white Delrin striker bush (B) and metal driving link (A) and fit metal striker ring (C), Part Number 1229618.
2. Any other trafficator switch complaint, replace switch Part Number 1223746 or 1223747 as applicable.

From: Super Minx III - B.14008219 to B.14011281
Minx V - B.03508644 to B.03511758

ROOTES MOTORS INCORPORATED

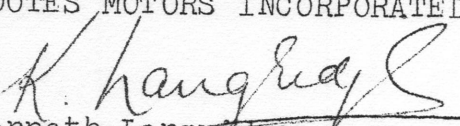
Kenneth Langridge
General Service Manager

KL/jd
Enc. - Illustration #8069

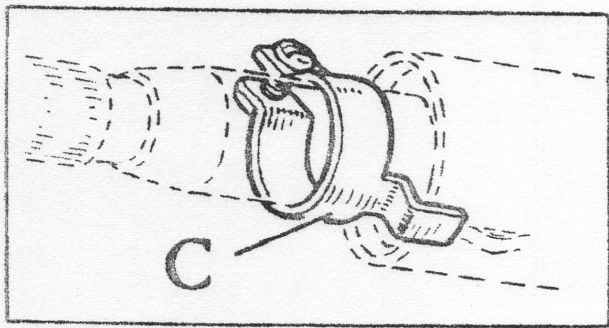
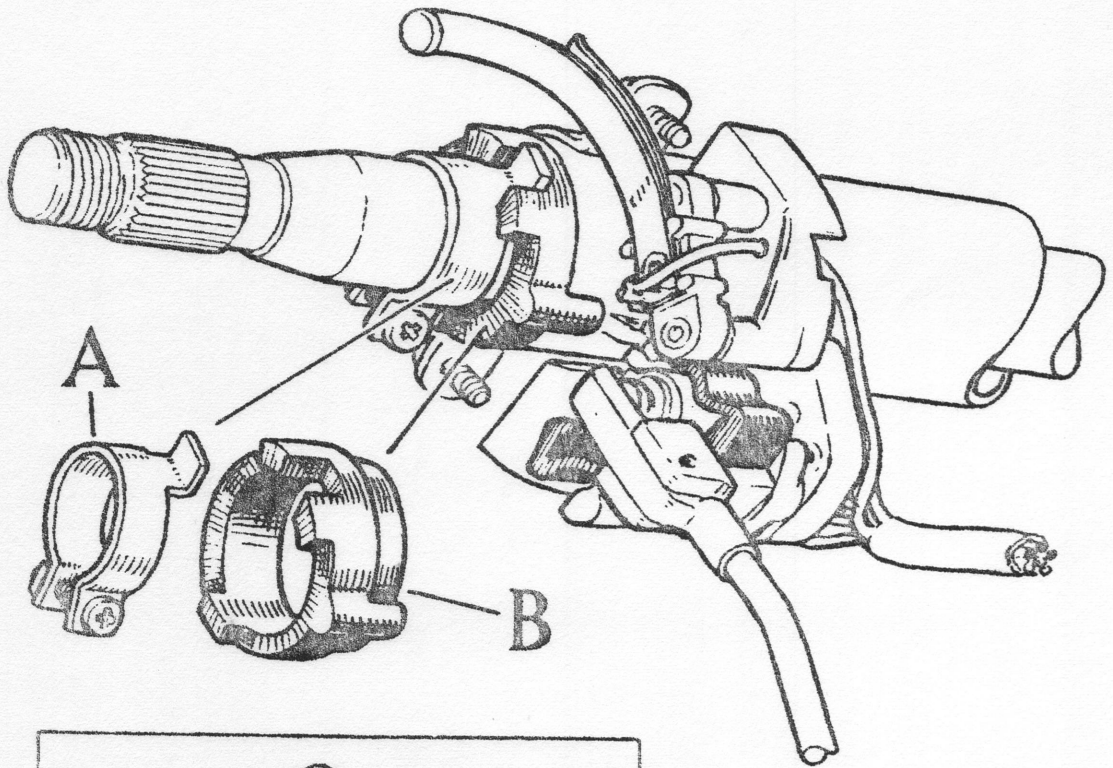

8069