

GENERAL DATA

65-8

No.

PAGE I OF II
NOVEMBER, 1965

TO: ALL ROOTES DEALERS
MODEL: ALL MODELS
SUBJECT: SELF CENTRALIZING SEALING WASHERS

Various plugs on all models are now fitted with self-centralizing sealing washers, in particular the filler and drain plugs on gearbox, rear axle, etc.

Should it be necessary at any time to refit or replace these washers, it is important to ensure that the smaller internal diameter of the washer is placed towards the head of the plug as shown in the attached illustration.

These washers must not be forced over the plug threads but screwed on until the smaller diameter engages the waisted section between the threads and plug head.

Please advise your Parts Manager of this information.

ROOTES MOTORS INCORPORATED

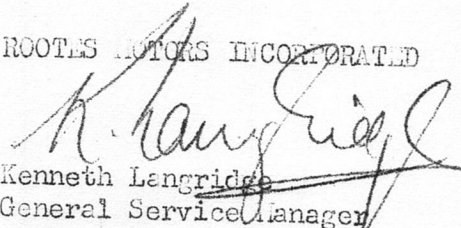
Kenneth Langridge
General Service Manager

KL/jd
Sketch Attached

Smaller Dia.

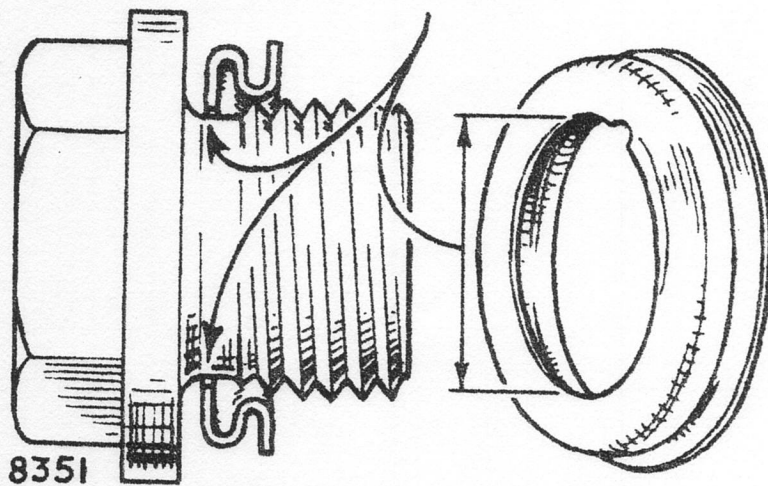

8351