

HILLMAN SUPER MINX

No. 62/4

POOR HEATER/DEMISTER PERFORMANCE

Sheet 1 of 2

Where complaints of heater inefficiency are reported, it is important to ensure that the main air mixing valve within the heater is properly seating in the vertical position, when the 'Heat and Car' control is set to 'Hot'. See Fig. 1.

This can be checked and rectified as follows:

1. Remove the blower to gain visual access to the air mixing valve.
2. Set the 'Heat and Car' control to 'Hot' and check that the air mixing valve is fully closed in the vertical position. Observe this through the heater air inlet aperture in the blower recess. See Fig. 1.
3. If the valve is not seating correctly, re-adjust the 'Heat and Car' control cable at the heater unit end as follows: -

Release the water valve plastic cover. (Note that the lower outer securing screw is locked by means of a nut, at the lower heater bracket inside the car. See Fig. 2. Right Hand Inset.) Do not lose the packing washer fitted between the bracket and the bulkhead.

The retainer plate and the plastic cover can now be eased away to allow access to the water valve lever and trunnions A and B. Fig. 2.

Release trunnion screw A, ensuring that the water valve lever is fully forward (open). Close the air mixing valve to the vertical position by hand and re-tighten screw A. Should the connecting rod between the water valve lever and the air mixing valve restrict the closure of the valve, release trunnion screw B, close the valve by hand and re-tighten screw B.

Remove any surplus inner cable, if necessary, after the adjustment is complete and before refitting the plastic cover.

4. Check action of control to ensure proper closure of the air mixing valve at 'Hot'.
5. Refit the plastic cover, ensure that the lower screws, distance tube, packing washer etc., are correctly positioned as shown.
6. Before refitting the blower, ensure that the seal fitted between the bulkhead and the heater body is properly positioned and compressed to avoid an air leak at this point. This seal, Part No. 1207482, is shown in the illustration in Section ZU of the Parts List.

Take care when refitting the blower that the seal is not displaced and the rubber band on the blower outlet correctly located.

If complaints of insufficient demisting action are recorded, the screen outlets should be checked to ensure they are not obstructed by the screen weatherstrip or the crash roll trim.

MISS PROC.
BODY

No. 62/4

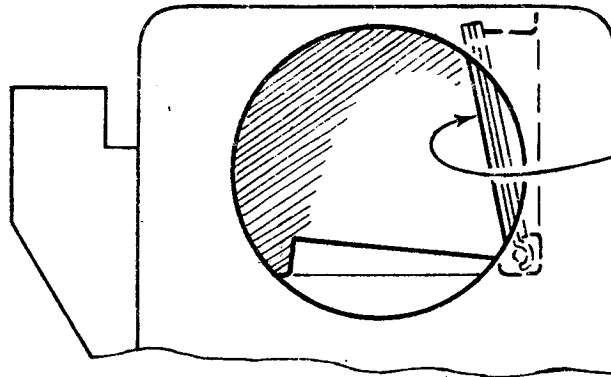

AIR
MIXING
VALVE

Fig. 1.

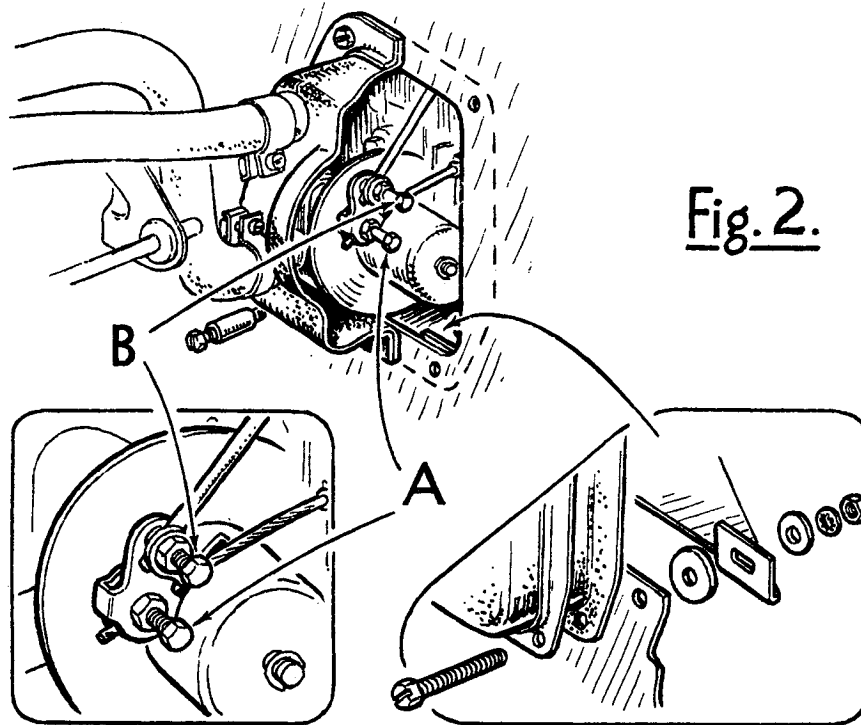

Fig. 2.

6254